



# TMR for 2D Angle Sensing

## 1 Abstract

*This paper covers the construction and operational principle of TMR-based angle sensor produced by Crocus Technology. The main sources of Angular Error in 2D sensors are explained in this paper.*

## 2 xMR for Automotive and Industrial Applications

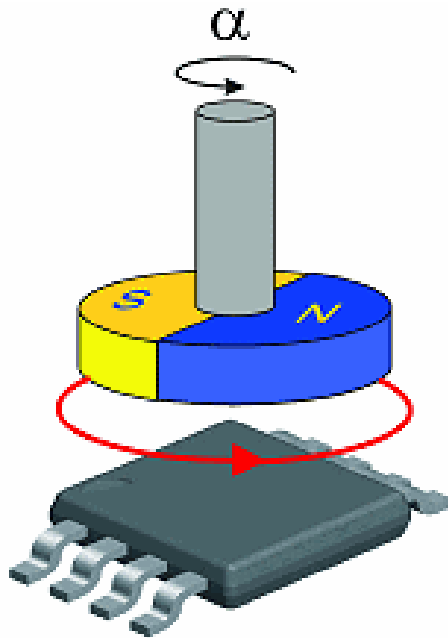

**Figure 1.** Angular sensor to measure the magnetic field angle of the shaft end.

Although xMR based sensors are relatively new, they have already entered various industrial and automotive applications. Due to the magnetic measurement principle, high sensitivity and low noise, they are very well suited for a wide range of different applications in the field of angle and speed sensing (see Figure 1). Examples of the target applications in industrial and automotive environments are:

- Steering angle measurement.

- Rotor position measurement for motor communication in a Brushless-DC (BLDC) motors.
- Speed sensing for wheel speed measurements (ABS sensor).
- Crank shaft speed and position sensing with direction information.

To address the above applications, Crocus Technology developed a special TMR angle sensor (2D sensor) which can provide information about the shaft angle, rotation direction and rotation speed in real-time.

Crocus' TMR angular sensor works under the same physical principle as all the other TMR/GMR-based magnetic sensors. The basic construction unit of TMR magnetic sensor is a Magnetic Tunnel Junction (MTJ) which consists of a Pinned and Free (Sense) layers separated by a dielectric barrier (see Figure 2). The Sense layer magnetization changes its magnitude and orientation if the external magnetic field changes occur. That leads to changes in the MTJ resistance.

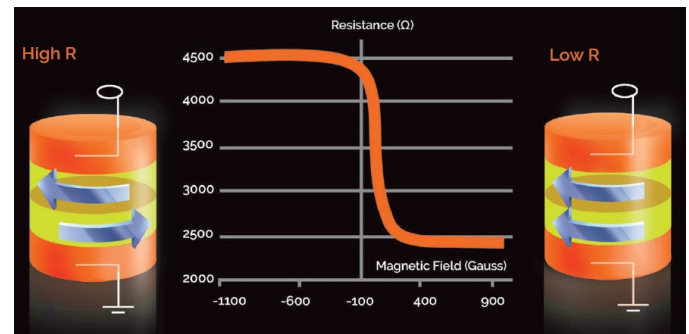

**Figure 2.** TMR physical principle for the example of a single Magnetic Tunnel Junction (MTJ). The MTJ resistance depends on the magnitude of the external magnetic field.

However, there is one important difference between a TMR angular sensor and a TMR linear magnetic sensor. TMR sensors usually work in the linear



range of TMR characteristics (see Figure 2) whereas angle sensor is in the saturated region. In other words, the Sense layer magnetization is always at the maximum possible magnitude and changes its orientation vector together with the external magnetic field angle. The Sense layer is kept always in saturation in order to achieve the best possible performance indicators which will be discussed in the next section. The obvious limitation of such approach is that the angular sensor can't operate at low magnetic fields. The typical angular sensor's operational magnetic field range is between 25 mT and 90 mT.

### 3 TMR Analog 2D Sensor

#### 3.1 Basic Construction

A TMR angular sensor (2D sensor) consists of eight TMR resistors that are sensitive to the magnetic field. Each resistor is constructed from a number of MTJs (TMR elements). Eight (8) resistors are connected into two Wheatstone bridge circuits, four (4) resistors in each bridge circuit (see Figure 3). Every TMR resistor is pre-programmed magnetically so it is sensitive to the magnetic field in certain directions. Moreover, two (2) neighbor branches are configured to change resistances with opposite signs to each other. For example, R1 and R2 in Figure 3 will change its values in opposite directions while external magnetic field is applied. As a result, a TMR angular sensor consists of two (2) bridges which are sensitive to linear components of an external magnetic field that is perpendicular to each other's direction.

Essentially, each full bridge is a linear magnetic sensor designed to measure a projected external magnetic field on its axis of sensitivity. The sensitivity axes of X and Y bridges are designed and implemented to be perfectly 90° to each other.

Both bridges are designed to be biased with constant  $V_{DD}$  voltage as shown in Figure 3. The output of each sensor consists of two (2) differential voltage signals, X and Y.

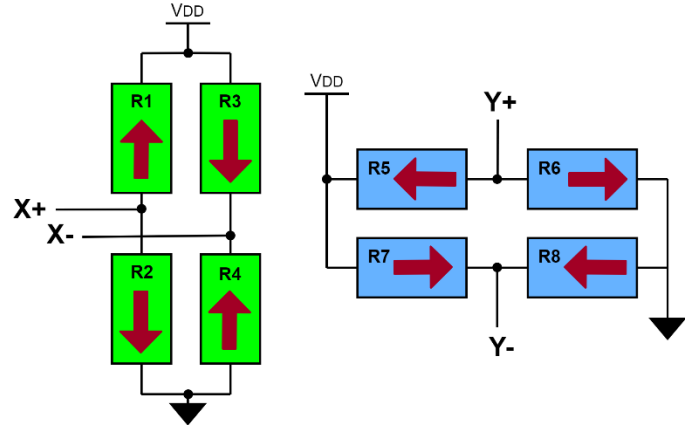

**Figure 3.** Basic construction of TMR angular sensor. R1, R2, R3, R4 Wheatstone bridge is sensitive to north/south orientation of magnetic field (X). R5, R6, R7, R8 Wheatstone bridge is sensitive to east/west orientation of magnetic field (Y).

#### 3.2 Principle of Operation and Calibration

The operation principle of a TMR angular sensor is based on the fact that two (2) bridges, X and Y provide harmonics that are identical to each other's voltage response versus the magnetic field angle but shifted 90° to each other. In other words, the X bridge response is a sine function of the magnetic field angle and the Y bridge response is a cosine function (see Figure 4).

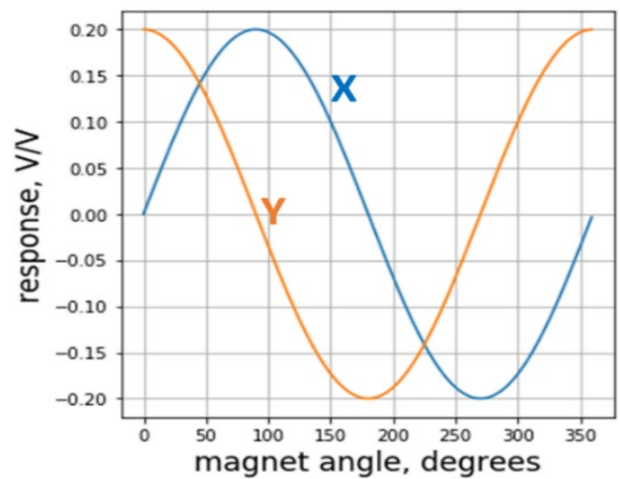

**Figure 4.** X and Y bridge responses as a function of external magnetic field angle.



It is always necessary to bias each bridge with a  $V_{DD}$  voltage that is between 1.0 V and 5.5 V. Each bridge's response is measured in Volts and characterized in Volts per bias Voltage.

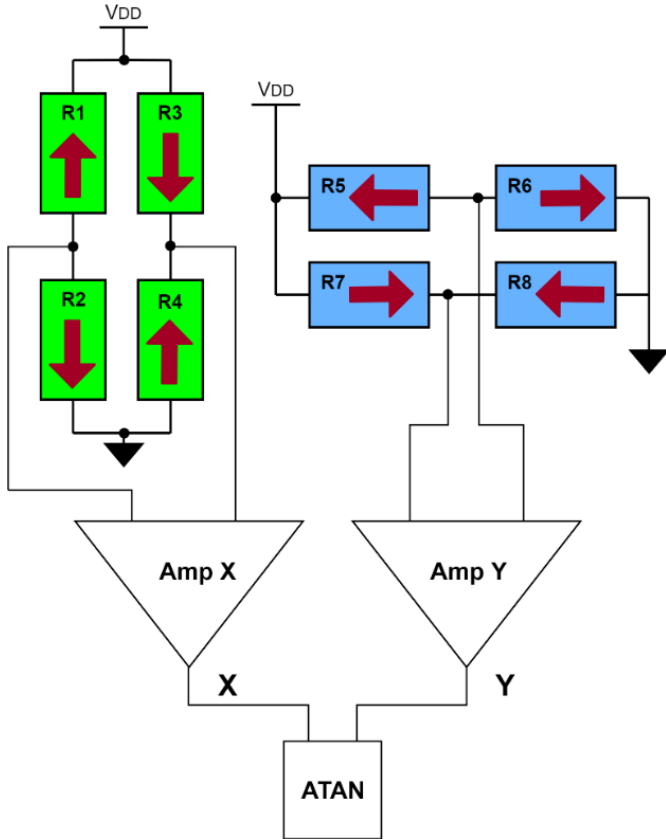

**Figure 5.** TMR angular sensor's X and Y bridges together with read-out circuit block diagram and arctangent calculation block.

As seen in Figure 4, both bridges separately provide measurement of only one half of the external magnetic field angle range. For example, the X bridge has the same voltage response for 45° and 135° magnet positions. In order to get a full 0° to 360° angle range measured one has to perform simple arctangent operation with X and Y responses:

$$\alpha = \arctan\left(\frac{Y}{X}\right)$$

The X and Y bridges of the angular sensor's responses are differential analog voltage signals. In

most cases it is necessary to convert differential signals into a single-ended signal before the arctangent calculation. In certain applications, additional signal correction and conditioning are necessary to achieve better sensor performance (see section 3.3). In Figure 5, "Amp X" and "Amp Y" blocks schematically represent read-out circuits needed for proper X and Y signals acquisition and conditioning before the arctangent calculation.

There are three (3) methods to calculate the arctangent with X and Y signals from the xMR angular sensor:

1. MCU (Microcontroller)
2. CORDIC (Coordinate Rotation Digital Computer)

### 3.3 Angular Error

The TMR angular sensor is designed to achieve precise measurement of uniform magnetic field angles. By far the most critical parameter of any angular sensor is the Angular Error (AE). A typical example of Crocus Technology's angular sensor AE as a function of the measured angle measured at a constant field and constant temperature is presented in Figure 6. The Angular Error versus the measured angle dependence consists of a number of sine and cosine harmonics which arise due to certain magnetic imperfections in the TMR magnetic layers. Internal magnetic and electric properties of TMR magnetic layers have various dependencies due to temperature changes across all field magnitudes within a working range. With its proprietary and patented TMR-based magnetic technology, Crocus' TMR 2D sensor achieves superior AEs. The amplitude of Angular Error dependence (as shown in Figure 6) is usually used as a figure of merit for the maximum Angular Error at a given magnetic field magnitude and temperature point. For example, the AE dependence in Figure 6 was measured at 40 mT field and at room temperature (+25°C).

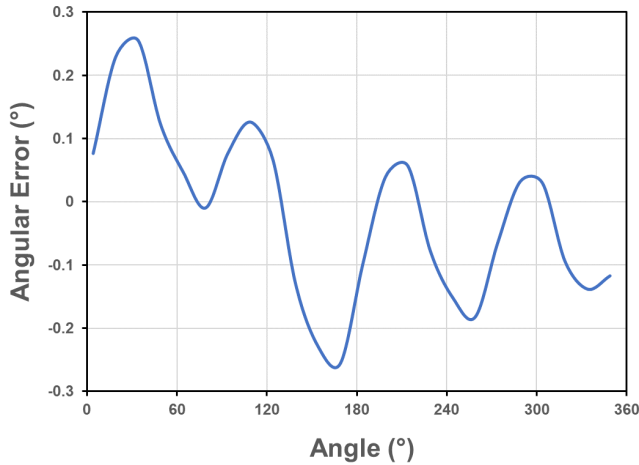

**Figure 6.** Example of Angular Error (AE) as a function of the magnetic field angle measured at room temperature at a single magnitude rotating magnetic field.

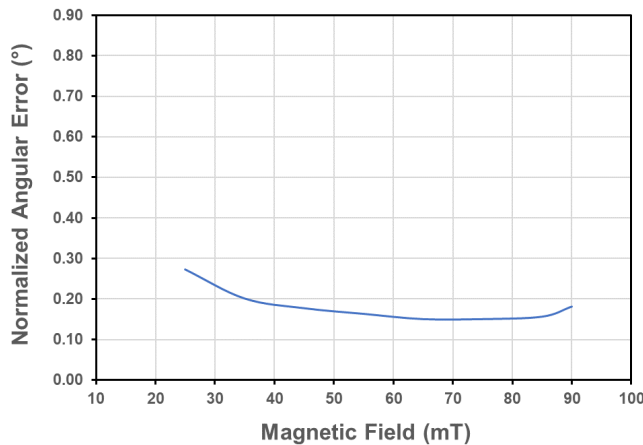

**Figure 7.** Example of Normalized Angular Error versus the magnitude of a rotating magnetic field measured at room temperature.

Crocus’s proprietary XtremeSense® technology allows TMR 2D sensor AE values to be below 0.6° within the whole working field range, from 25 mT up to 90 mT. The typical AE versus magnetic field dependence is illustrated in Figure 7.

## 4 Implementing CT310 in Systems

As indicated on the Recommended Application Circuit (Figure 8) in the CT310 data sheet, both bridges (COS and SIN) should be powered

simultaneously with identical  $V_{DD}$  voltages in the range of 1.0 V to 5.5 V. ESD protection is already implemented inside of the CT310 sensor circuitry.

The outputs from both bridges (COSP, COSN and SINP, SINN) are differential analog signals and these signals should be digitized first, in order to allow numerical arctangent calculations (see 3.2).

The first way to digitize the sensor’s signal is to connect them to differential input Analog-to-Digital Converters (ADCs), one ADC per each bridge output. However, differential ADCs are not always available, especially in the case of microcontroller systems. A regular single-ended ADC could be used if signals are brought to single-ended modes using instrumentation amplifiers (see Figure 8). In case of battery-powered applications, where voltages are DC it is necessary to shift the reference voltage point on the Instrumentation Amplifier (INA) to  $V_{DD}/2$  level. That will allow differential signals to be always above 0 V.

Standard inverse tangent functions return angle values ranging from  $-90^\circ$  to  $+90^\circ$ . For this application, it is important to use a four quadrant arctangent function to return an angle from  $-180^\circ$  to  $+180^\circ$ . This function also avoids issues with dividing by 0. Four quadrant inverse tangent functions are listed in the table below.

Program	Function	Description
MATLAB	$atan2(Y,X)$	Result in radian
	$atan2d(Y,X)$	Result in degrees
ARDUINO	$atan2(Y,X)$	Returns double
	$atan2f(Y,X)$	Returns float
C#	$Atan2(Y,X)$	Returns double
Python	$NumPy.arctan2(Y,X)$	Returns double

**Table 1.** Arctangent functions for MATLAB, ARDUINO, C# and Python programs.

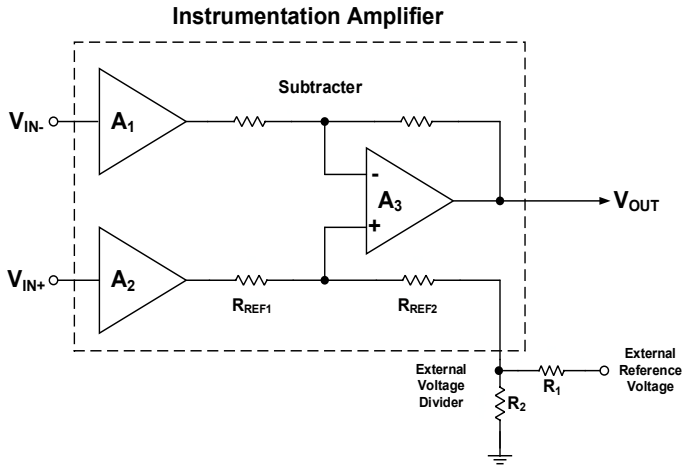

**Figure 8.** Conversion of differential analog signal into single-ended one with reference voltage shift on the INA.

## 5 Conclusion

Crocus Technology's TMR based 2D sensor offers the best alternative to older magnetic 2D sensors. Advantages include: lowest power consumption, low Angular Error and a cost-effective solution due to the high CMOS integration capability which enables a monolithic IC (integrated circuit).