



# From Hall Effect to TMR

## 1 Abstract

*This paper compares the century old Hall effect technology to xMR technologies, specifically TMR (Tunnel Magneto-Resistance) from Crocus Technology. It covers the various concepts behind all technologies and the major differences between the end-products.*

## 2 Introduction

There is a multitude of systems to transduce a magnetic field to a proportional voltage. These magnetic sensors have been implemented into different applications within different industries. Some applications include: magnetic encoders, e-compass, absolute angle sensor, simple on/off switch, current sensing.

Hall-effect was discovered by Edwin Hall in 1879. After more than a century of development, Hall effect sensors have reached limitations that are forcing system designers to search for new technologies to achieve their targets of: power consumption, sensitivity, accuracy, and cost.

TMR technology is the natural evolution of older technologies like GMR and AMR. This paper will provide a very high-level introduction to the different technologies by understanding the physics behind every phenomenon. Then, the paper gives an in-depth look at Crocus Technology's TMR solution.

## 3 The Physics

### 3.1 Hall Effect

Conceptually, it is simple to setup a demonstration of the Hall effect. Illustrated in Figure 1, the Hall effect demonstrator requires a thin plate of conductive material, carrying current ( $I$ ) generated

by a DC voltage supply and a voltmeter connected to the sides of the conductive plate.

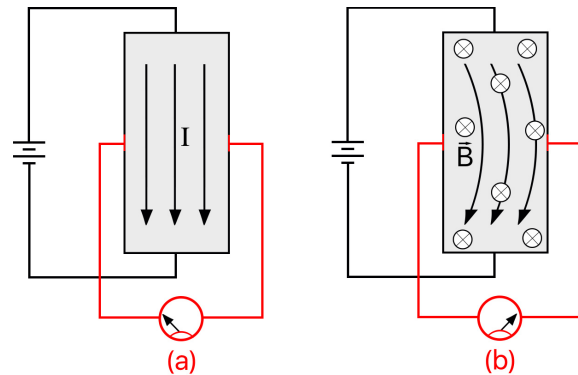

Figure 1 The Hall effect in a thin plate.

Under no magnetic field, the voltmeter should read 0 V in Figure 1 (a). However, when a magnetic field, perpendicular to the current flow, is applied to the plate, a small voltage appears across the plate, which can be measured by the voltmeter Figure 1 (b).

The separation of charge establishes an electric field that opposes the migration of further charge, so a steady electrical potential is established for as long as the electrons are flowing. The force that pushes charged particles such as electrons is called the Lorentz force and is described by the following equation:

$$\vec{F} = q_0\vec{E} + q_0\vec{v} \times \vec{B}$$

Equation 1 Lorentz Force Equation.

$\mathbf{F}$  is the resultant force,  $\mathbf{E}$  is the electric field,  $\mathbf{v}$  is the velocity of the charge,  $\mathbf{B}$  is the magnetic field and  $q$  is the magnitude of the charge.

This equation represents two separate effects: the response of a charge to an electric field and the response of a moving charge to a magnetic field. When a magnetic field is applied to a moving charged particle, it experiences the Lorentz force.

### 3.2 Hall Effect in Semiconductors

The Hall effect's thin plate can be implemented in a CMOS process. This enables semiconductor companies to develop various products based on Hall effect technology.

Typically, the conducting plate will be grown directly on the substrate by doping the silicon with different materials to create either n-type or p-type carrier regions. The doped region is then connected to the rest of the circuit with the help of metal VIAs (Vertical Interconnect Access).

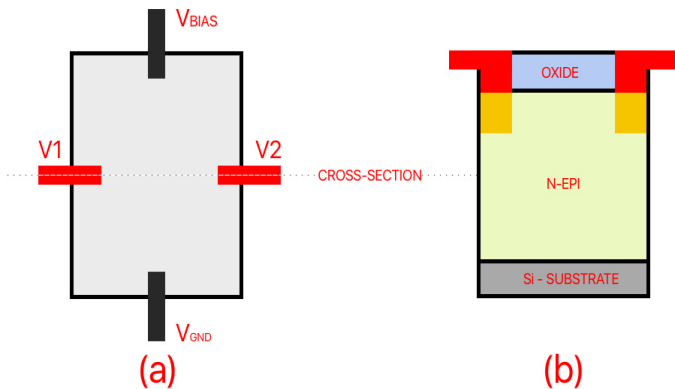

Figure 2 Cross section of a single Hall element.

Figure 2 (a) shows a top view of a Hall effect plate implemented on CMOS substrate, Figure 2 (b) shows the cross section where N-epi doped silicon is shown.

### 3.3 Magneto-Resistance

Magneto-Resistance is the property of a device to change its electrical value under a magnetic field.

This effect is observed in ferromagnetic materials: these are materials that have magnetic properties. Metals like iron (Fe), nickel (Ni) and cobalt (Co) are ferromagnetic while copper (Cu) is not a ferromagnetic material. Changing the magnetization of the material affects how the electrons travel inside the material, thus changing the electrical resistance of the device.

#### 3.3.1 Electron Scattering

Every electron has two key parameters: charge and spin. Every electron has the same charge -  $1.602 \times 10^{-19}$  C. However, an electron can have either a spin UP or a spin DOWN. This was experimentally proven in 1922, confirming that electrons possess an intrinsic angular momentum and a magnetic moment.

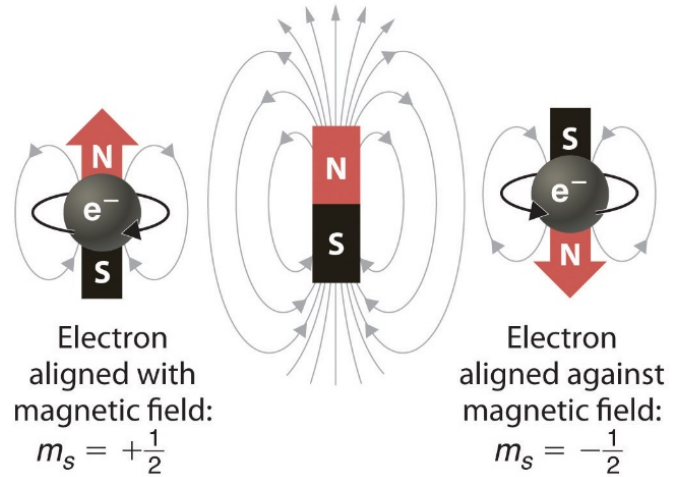

Figure 3 The two possible spin positions of an electron.

It is important to understand that the Lorentz force acts on the electrons due to their charge and that the magneto resistive phenomenon is due to the spin of the electrons.

When travelling inside a conductive material, the electron can scatter. Electron scattering refers to a phenomenon where electrons deviate from the normal trajectory due to electrostatic forces within the material.

The Lorentz force appears on a charged moving particle (i.e., electron) within a conductive material when subjected to a magnetic field. This force affects all particle with a charge and is independent of the electron spins.

When electrons travel inside a ferromagnetic material (i.e., material with a certain magnetization). The spin of electrons (either up or down) will increase or decrease their

scattering probability within the magnetized material. This is the origin of the MR effect.

### 3.3.2 AMR

The first discovery of this effect dates back to 1856 by William Thomson. The effect is referred to today as AMR (Anisotropic Magneto-Resistance).

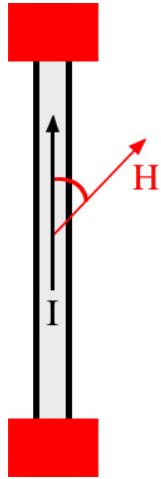

Figure 4 Single AMR element.

This effect can be easily demonstrated using a ferromagnetic material and a biasing current under an external magnetic field.

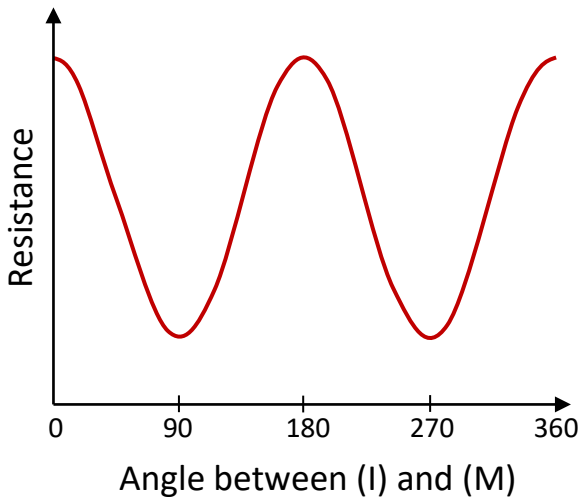
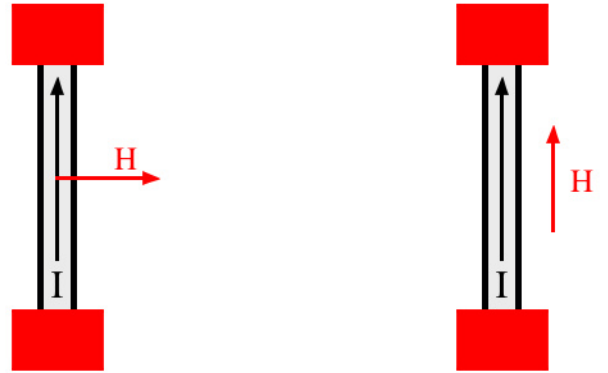

Figure 5 AMR element resistance change under rotating magnetic field.



Low resistance

High resistance

Figure 6 Two AMR elements under different magnetic fields.

When the magnetization,  $M$ , is parallel to the current,  $I$ , the resistance reaches its maximum value as electronic orbits are perpendicular to current, this in turn increases the spin dependent scattering thus increasing the electrical resistance. Conversely, when the magnetization ( $M$ ) is perpendicular, the electronic orbits are parallel to the current reducing the spin dependent scattering which leads to a lower resistance value.

Because of the simplicity and ease of CMOS integration of this phenomenon, multiple types of devices make use of this technology for various application and these products are made available from several semiconductor companies such as: Honeywell, NXP and ST.

The biggest limitation of this technology is the MR effect itself which is the change in resistance from its maximum to minimum values. It is usually limited to a 5% change.

### 3.3.3 GMR

Giant Magneto-Resistance (GMR) was first discovered in 1988 independently by Albert Fert and Peter Grünberg. Both were later rewarded the Nobel Prize in 2007 for this discovery.



GMR is observed in thin-film structures composed of alternating ferromagnetic and non-magnetic conductive layers.

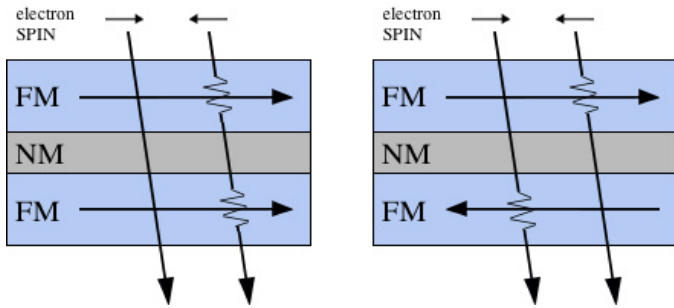

Figure 7 GMR structures showing spin-dependent scattering.

The magnetization of both ferromagnetic layers will impact the spin-dependent scattering of electrons travelling inside the junction.

Electrons traveling through the ferromagnetic layer interact with it much weaker when their spin directions are opposite to the magnetization of the material than when they are parallel to it.

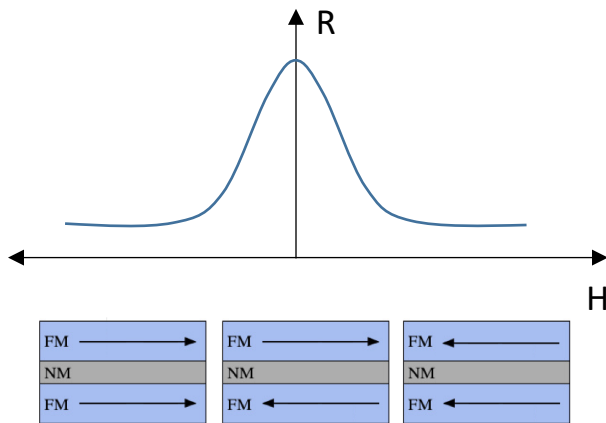

Figure 8 GMR element response under different configurations.

GMR revolutionized the hard-drives by making the reading head smaller than the usual coil. This allowed for smaller storage magnets on the hard-disk which then lead to higher storage capacities on the hard-drives.

However, GMR is still limited by the percentage change between high and low resistance states, typically around 20%.

### 3.3.4 TMR

Tunnel Magneto-Resistance (TMR) was first discovered in 1991 by Terunobu Miyazaki. The main difference between GMR and TMR was in the non-magnetic layer.

TMR requires the use of an extremely thin non-magnetic and non-conducting insulation layer between the ferromagnetic layers. If the insulating layer is thin enough (typically a few nanometers), electrons can tunnel from one ferromagnet into the other. Since this process is forbidden in classical physics, the tunnel magneto-resistance is a strictly quantum mechanical phenomenon.

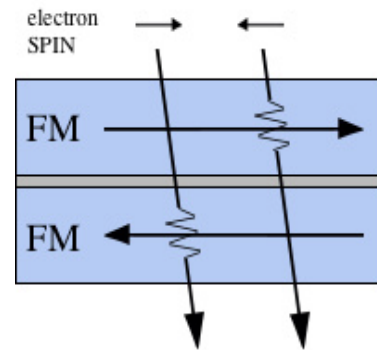

Figure 9 TMR junction showing two Ferromagnets and a tunnel barrier.

The MR effect in TMR junctions can reach more than 100% in production. In lab conditions, levels upwards of 1,000% were achieved.

### 3.3.5 Signal Amplitude – MR Effect

TMR offers the best sensitivity compared to Hall, AMR and GMR. This is shown on the graph below that represents the change of resistance or the Magnetoresistance when a rotating magnetic field is applied.

Another advantage that TMR and also GMR offer compared to AMR is the ability of the magnetic junction to sense a 360° applied field.



This offers a great advantage when designing an absolute angle sensor.

Note that the graph below is not made to scale to be able show the sinusoidal signal of AMR. The percentage numbers on the graph represent the change of resistance from  $R_{MIN}$  to  $R_{MAX}$  for every signal.

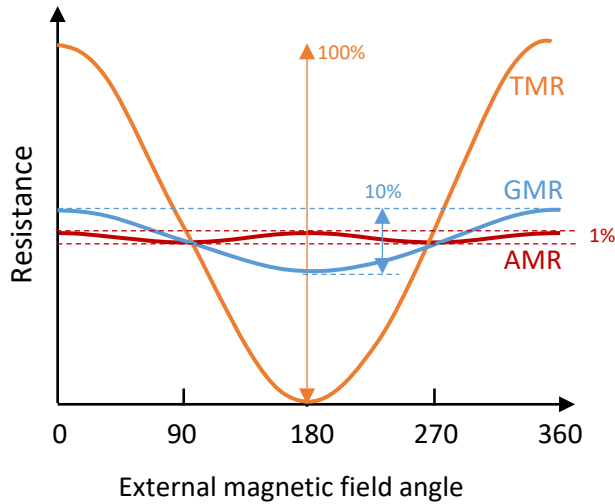

Figure 10 Not to scale, Signal amplitude comparison AMR, GMR and TMR

Another method to visualize the difference in sensitivity between the three main MR technologies is shown below.

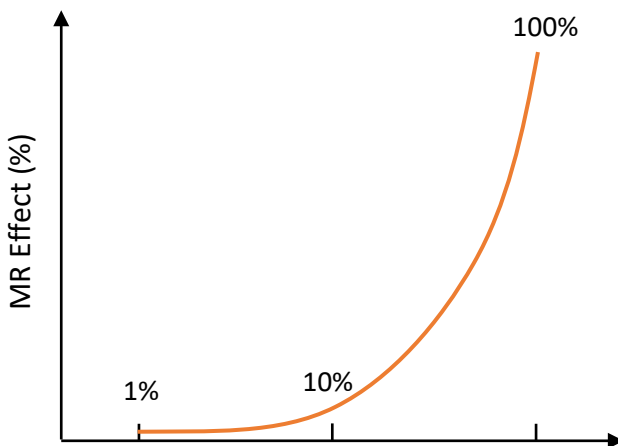

Figure 11 MR effect comparison

## 4 TMR from Crocus Technology

Many teams around the world have now demonstrated TMR junctions in their respective labs. However, very few companies have committed to moving this technology into full-fledged products.

Crocus Technology does not own a CMOS foundry. It operates as an IP provider, offering any foundry the opportunity to add TMR technology to their portfolio.



Figure 12 Typical CMOS structure.

Another advantage of this technology is that it is deposited during BEOL (Back-End-Of-Line). This means that compared to Hall effect sensors which are deposited during FEOL (Front-End-Of-Line), Crocus Technology's TMR sensors do not take precious space on the substrate. Crocus Technology has developed extensive expertise in depositing the TMR sensor between metal layers especially dealing with mechanical stress over the junctions.

## 5 Conclusion

Crocus Technology's TMR offers the best alternative to older magnetic sensors. Advantages include a high SNR, lowest power consumption in the nA range and a cost-effective solution due to the high CMOS integration capability which enables a monolithic IC.